

Self Closing Gate Instructions

There are three important components that make your pool gate operate properly. Please familiarize yourself with these three adjustments. Please ensure that your pool gate is properly aligned, properly tensioned, and latching correctly. If you have any questions regarding your pool gate please contact your original installer.

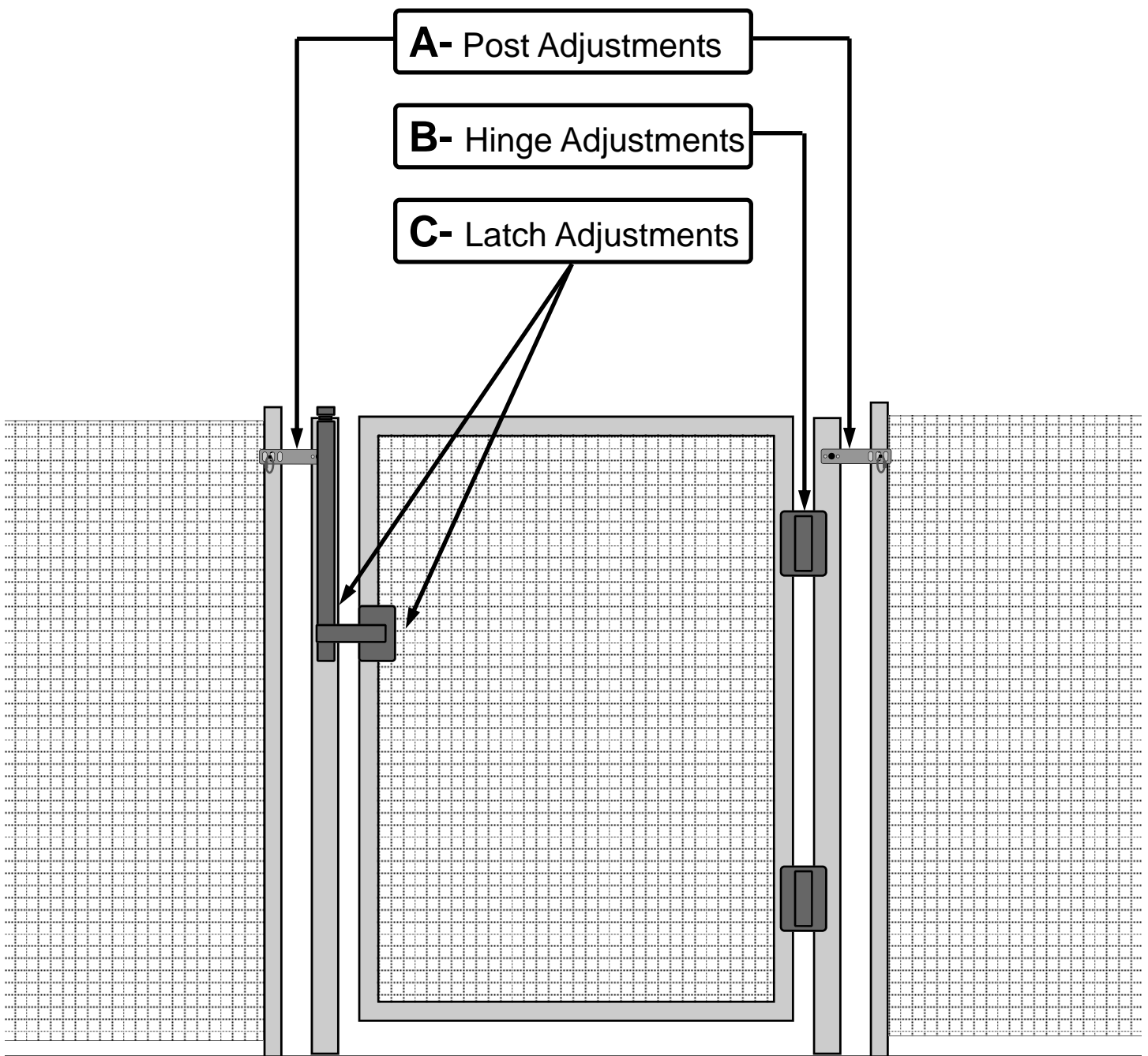

A: Gate Post Adjustment

Warning: Swimming pool fences, gates and latches cannot substitute for adult supervision.

It is critical that your gate closes and securely latches each and every time you open and close your pool gate.

To ensure proper closure of your gate, it is critical that your “Magnetic Gate Latch” aligns properly. It is possible for your gate to become misaligned, especially if someone hangs on the “Gate Frame”. Your gate is equipped with adjustable “Gate Brackets”. These brackets allow you to make minor adjustments the alignment of your “Gate Posts”. By properly aligning your “Gate Posts”, you will be able to ensure proper alignment of the “Magnetic Latch”.

Gate Post Adjustment:

Simply remove the “Quick Link”, reposition the “Eye Screw” to a different slot in the “Adjustment Bracket”, and replace the “Quick Link”. Check to make sure the gate closes properly and the latch engages properly.

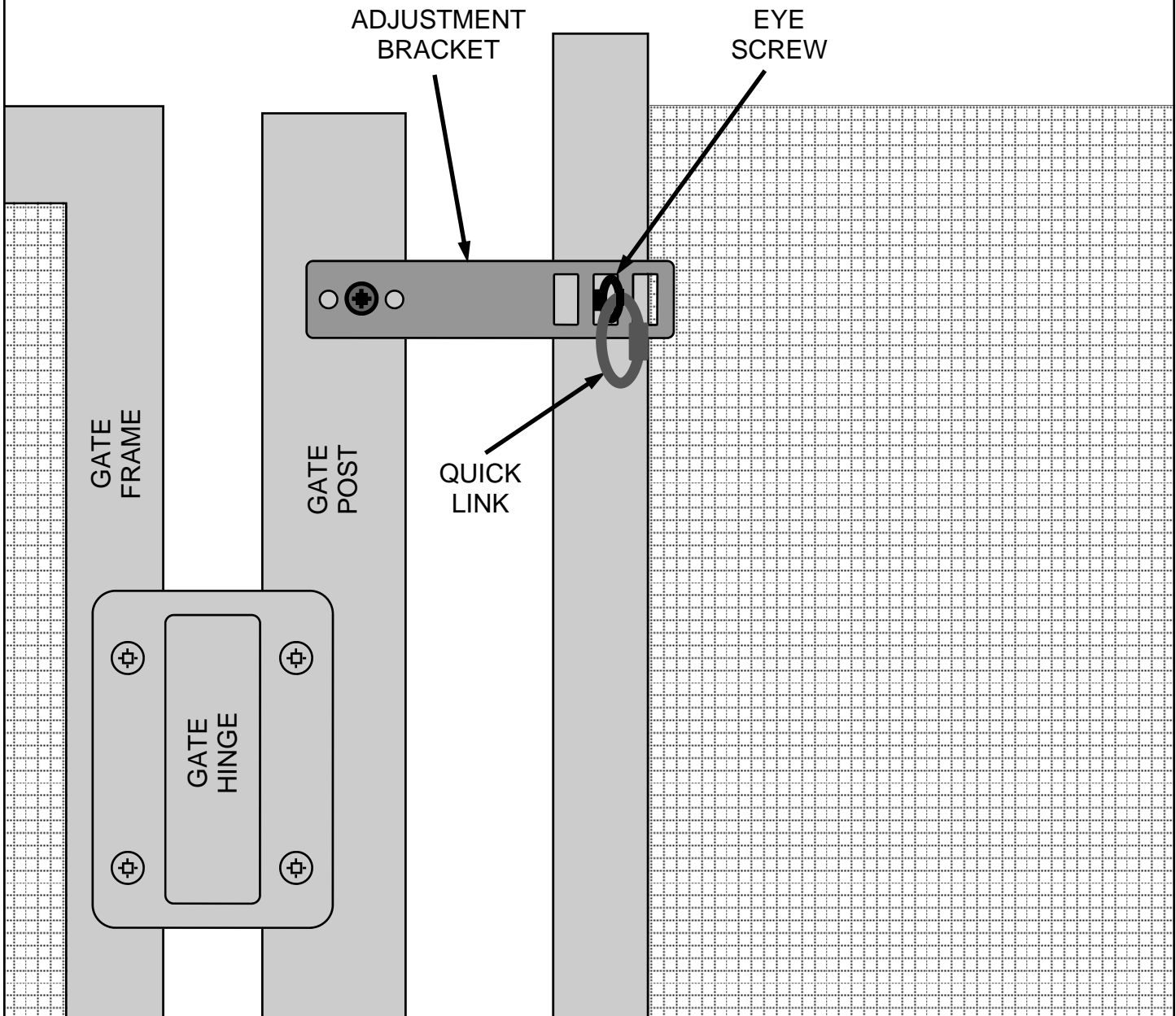

B: Gate Hinge Adjustment

Warning: Swimming pool fences, gates and latches cannot substitute for adult supervision.

It is critical that your gate closes and securely latches each and every time you open and close your pool gate. Your gate will not close and latch properly unless the "gate hinges" are properly tensioned. Properly tensioned gate hinges will automatically swing the gate closed. This tension should be verified each time the gate closes to ensure proper closure.

The unique design ensures the hinges can be finely adjusted for smooth closure at the turn of a screwdriver. This clever tension adjustment feature overcomes the typical fatigue problems.

Maintenance: Ensure proper closure of the gate frame each time the gate closes. Make appropriate adjustments to hinges as needed.

Tension Adjustment:

Simply remove the cap at the top of the hinge with a phillips screwdriver. Depress and rotate the internal adjustor with flat head screwdriver. The adjustor rises back into sleeve and the desired tension is fixed.

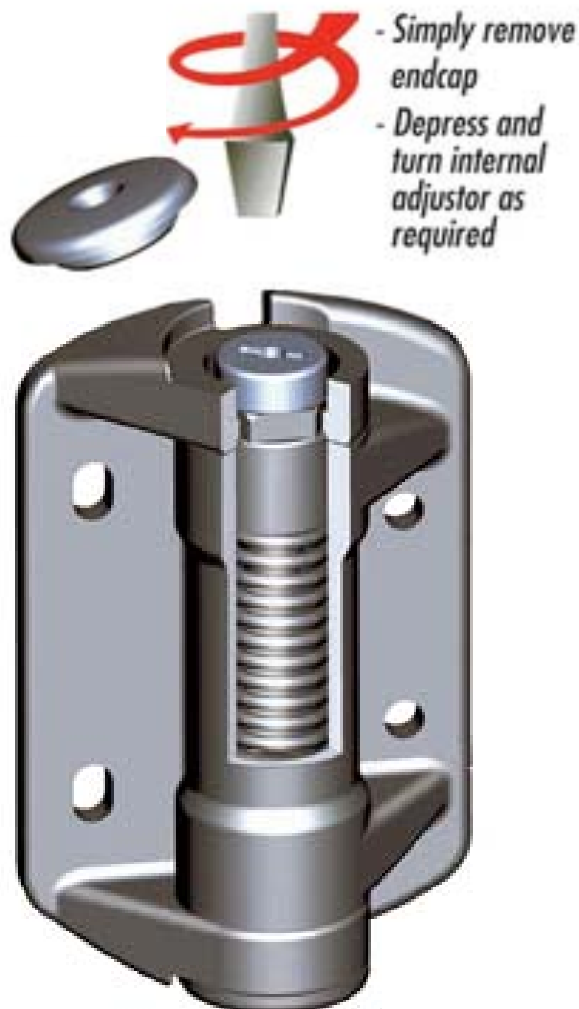

C: Gate Latch Adjustment

Warning: This is not a childproof latch. It offers child resistance only. Swimming pool fences, gates and latches cannot substitute for adult supervision.

It is critical that your gate closes and securely latches each and every time you open and close your pool gate. Your magnetic gate latch will not function properly if the "striker body" and "latch body" are not properly aligned. The striker body is adjustable left and right (horizontal) while the latch body is adjustable up and down (vertical). Together, these two adjustments allow you to properly align your magnetic gate latch. This alignment should be verified each time the gate closes to ensure proper latching.

If using this latch on a swimming pool gate, consult all appropriate local authorities for safety requirements. The latch will operate properly only if installed and maintained in accordance with these instructions.

Maintenance: Remove key from lock after use. Regularly lubricate the key-lock part of this latch by spraying oil-based lubricant into lock. Do not lubricate any other part of the latch. Ensure all screws or bolts are tightened firmly and that the release knob and latching bolt are kept free of sand, debris, or ice which could impair latch performance. Ensure proper alignment of the latch body and striker body each time

